

Hybrid Injection Molding Machine 100~3500 (US Tons)

# LSG-H SERIES

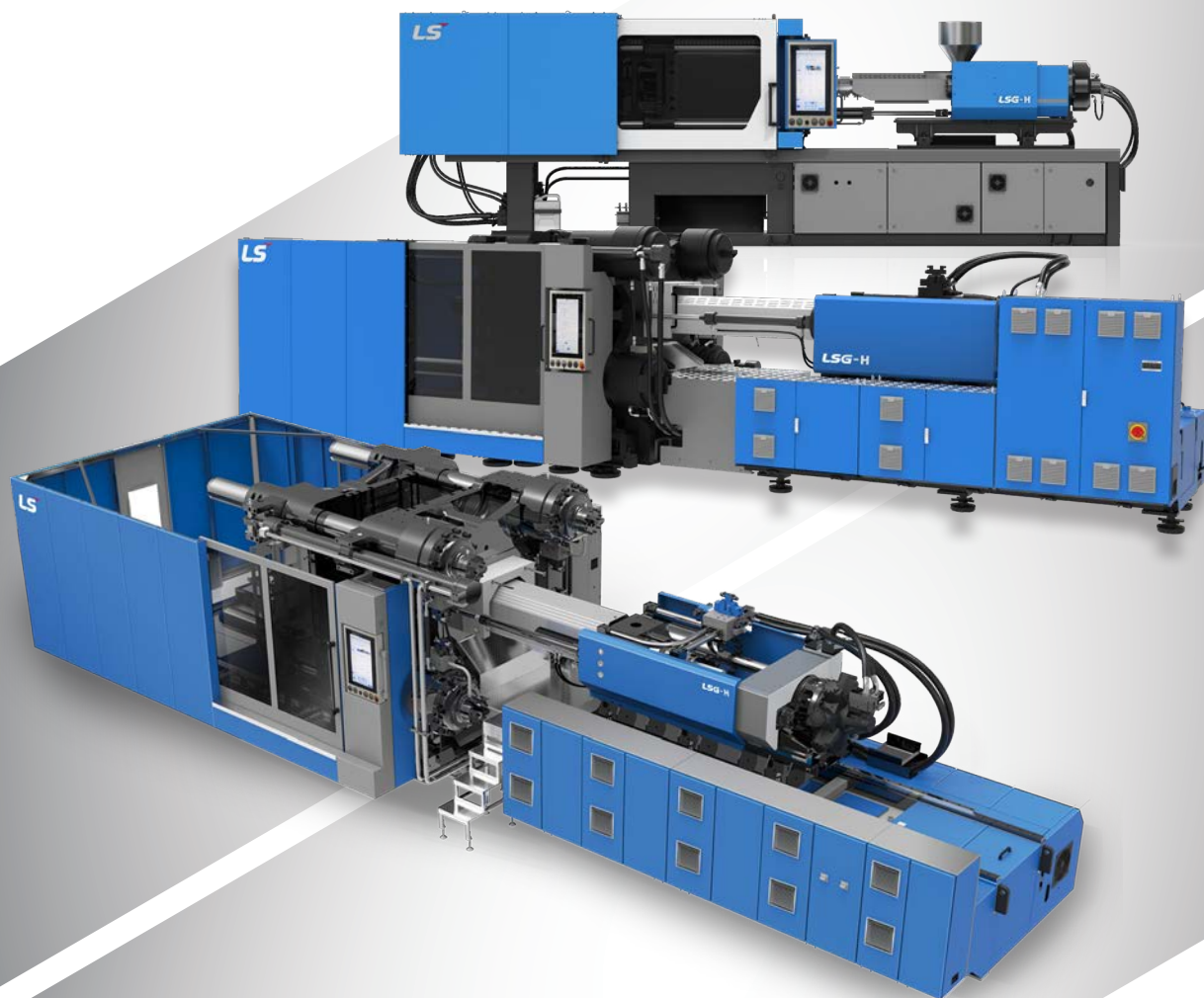



## About LS Mtron

LS Mtron, a subsidiary of the LS Group, a conglomerate based in South Korea, employs over 25,000 people and reports annual revenues exceeding USD 30 billion, with profits around USD 1 billion. The Injection Molding Machines division of LS Mtron (LS IMM) was established in 1969 by the South Korean tech behemoth LG Corporation, known as one of the largest plastic molders globally. Initially created to meet its demand for injection molded parts for their renowned TVs, appliances, electronics, and other products, LS IMM now manufactures approximately 3,000 machines annually. These machines cater not only to LS and LG-related companies but also to a global clientele of molders.

Originating with the invention of Korea's first Injection Molding Machines, LS IMM is celebrated for its commitment to quality, customer service, and rapid delivery times. Leveraging the collective capabilities of the LS Group's companies, LS IMM addresses several global supply chain challenges. This synergy enables LS IMM to offer custom molding machines to its customers in North America within just 100 days from casting to shipment, with the possibility of even quicker delivery times from its pre-stocked inventory.

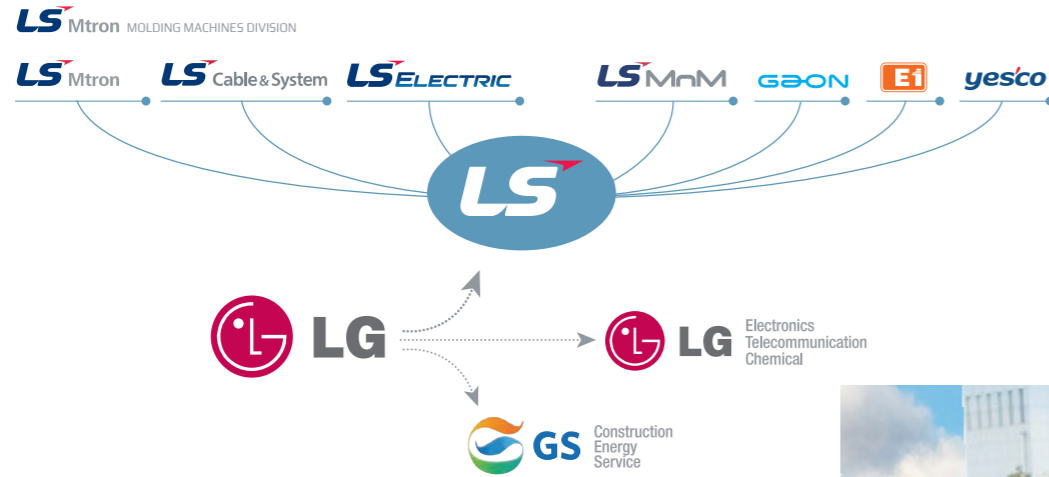

## Integrated ONE Solution Smart Machine for Industry 4.0 Delivering Value

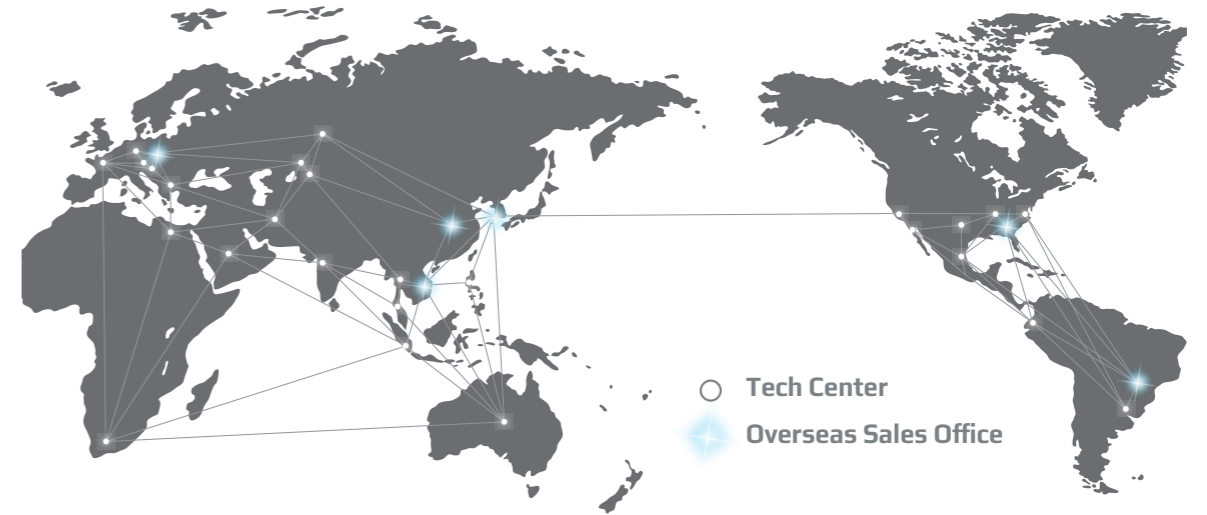

## INNOVATIVE TECHNOLOGY PARTNER



Compact Hybrid Injection Molding Machine

# LSG-H 100~420 (US Tons)



Fast Cycle Time



High Precision



Easy and Convenient Maintenance



Large Mold Weight Capacity



High Durability

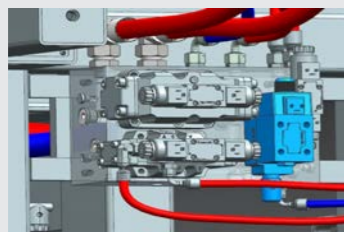

Oil Braking Circuit for Enhanced Clamp Accuracy

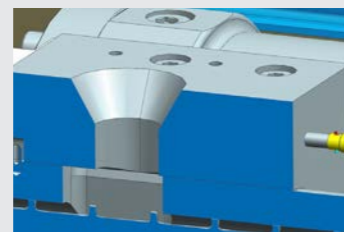

Optimal Barrel Temperature Sensor Positions

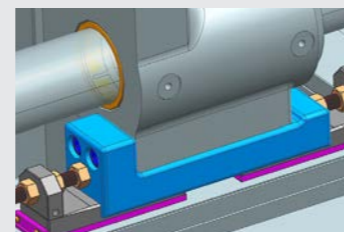

Graphite Impregnated Moving Platen Carriers

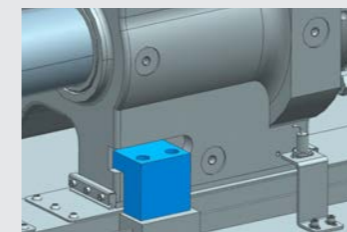

Moving Platen Adjustable Stopper

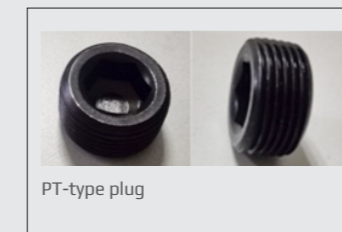

PT-type plug

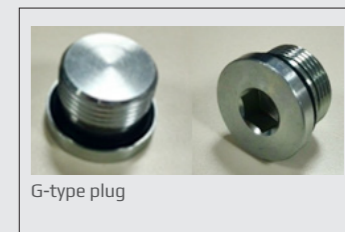

G-type plug

All Machine Hydraulic Fittings Changed from PT-Type to G-Type

Mid-Sized Hybrid Injection Molding Machine

# LSG-H 500~1100 (US Tons)



Energy Saving



Fast Dry Cycle Time



Large Plasticizing Capacity



Low Noise Level



0.07% Weight Deviation

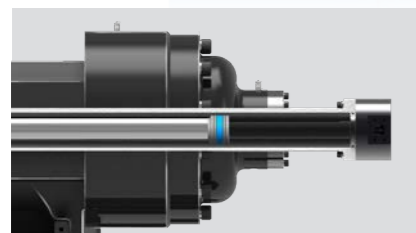

Leak Prevention Clamping Cylinder

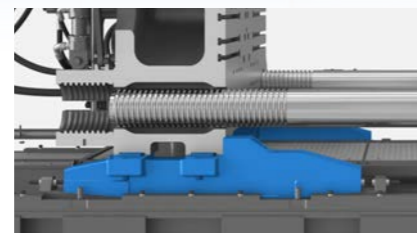

No Lubricant Sliding Bush

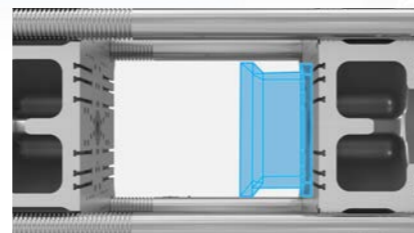

Heavy Mold Installation

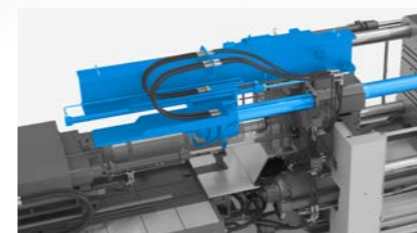

Tie-Bar Pulling System Option

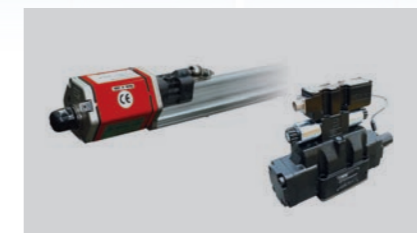

SSI Type High Precision Digital Sensor, Large Capacity Electronic Proportional Valve



Precision Control KEBA Controller

## High Performance Clamp Mechanism

### Tie Bar New Structure

- Structure design for prevention sag
- Embedded potentiometer

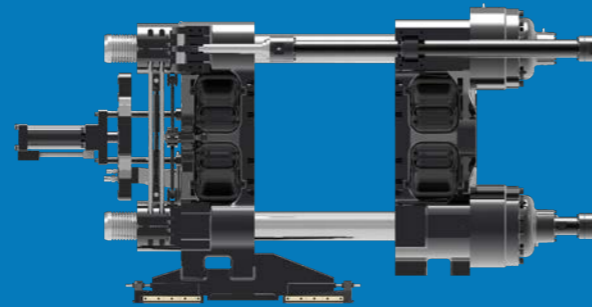

### High Rigidity Structure and Durability Improvement

- Long sliding support of 1.5% of clamping force for heavy molds
- High rigidity, optimized template design
- Eliminate tie-bar bush of moving platen and wear reduction, no lubrication

### Revolutionary Clamping Unit Oil Lubrication and Oil-Free Sliding Bush

- Minimize grease usage and create a pristine environment with advanced clamping unit lubrication oil, surpassing the conventional grease type.
- **Cutting-Edge Oil-Free Sliding Bush** : Experience reduced friction resistance and enhanced durability, setting new standards in performance.
- **Cost-Efficient Maintenance** : Significantly lower maintenance costs, ensuring long-term savings and efficiency.



### Improve Clamping Cylinder Structure

- Application high functional sealing technology, leak prevention
- Maintains pressure when boosting, power saving effect improvement
- Oil temperature maintenance improvement



## Advanced Productivity

### Fast Cycle Time by Quick Clamping Unit

- Shortening clamping time
- Half nut clamping error prevention
- High mold open & close speed by proportional valve (1,000mm/sec)
- Clamping noise minimization

## Improved Reproducibility of Mold Opening and Closing Position

### High precision digital position sensor



### High performance large capacity electromagnetic proportional valve

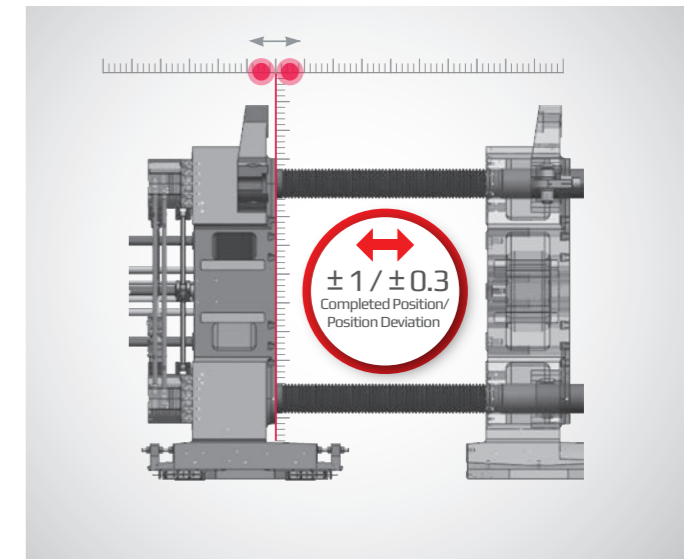

## Tie Bar Pulling System

[Option : Application above LSG 900H model]

### Tie Bar Puller Device Option

- One touch tie bar separation
- Easy mold replacement in low ceilings
- Investment cost reduction compared to truck facilities

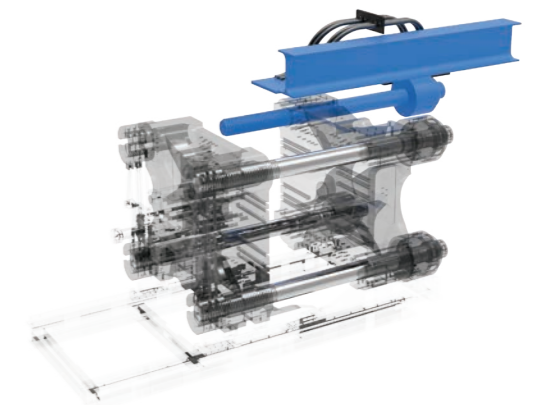

# Injection Unit Improvement

## Injection Unit Movement, Double Cylinder Application

- Double cylinders, Injection stability and resin leak improvement
- Extended life of hydraulic cylinders and plasticization parts

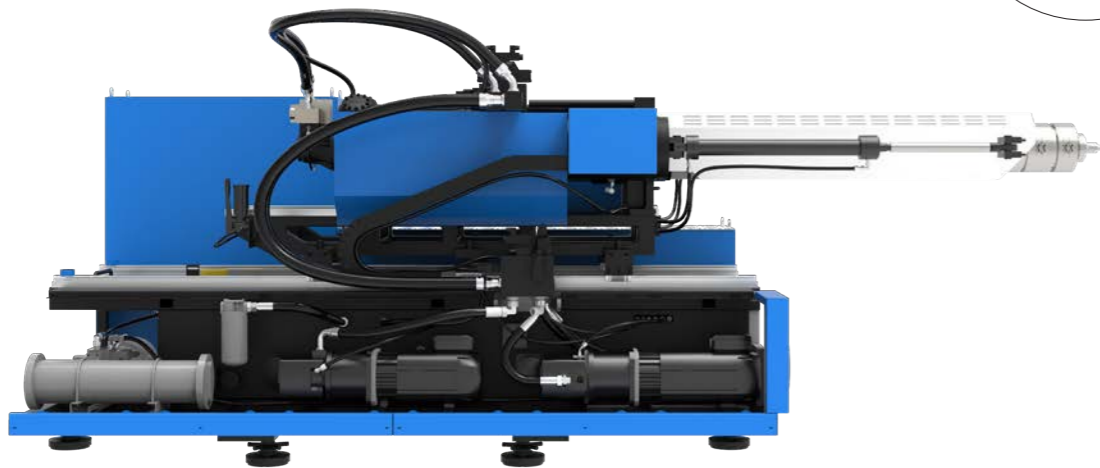

## Easy to Respond to Modulation

- Upper and lower injection device application
- Response with flexibility, High performance plasticization

LSG-H Mid-sized Hydraulic Machine Matrix

Model	LSG 500H	LSG600H	LSG 700H	LSG 900H	LSG 1100H
i28	65Y 70A 80B	65Y 70A 80B			
i35	70Y 75A 85B	70Y 75A 85B	70Y 75A 85B		
i61		85Y 90A 100B	85Y 90A 100B	85Y 90A 100B	85Y 90A 100B
i92			95Y 105A 115B	95Y 105A 115B	95Y 105A 115B
i118				105Y 115A 125B	105Y 115A 125B

## Increased Oil Cooling Efficiency

- Increased oil cooler capacity compared to the conventional Model → Enhanced Cooling Efficiency
- Maintains lower hydraulic oil temperature, improving machine operation reproducibility



## Cast Type Middle Frame

- Using the cast middle frame minimizes deformation (solves twisting caused by welding of welded structural parts)

## Commonization of Screw Parts

- Compatible with screws from the previous Conventional model

## High-Pressure Hydraulic Circuit

- Overall circuit pressure of 210 bar (compared to the main circuit pressure of 175 bar and clamping boost pressure of 187 bar in the LSG-H mid size)
- Reduced oil tank capacity due to decreased oil usage

	Unit	500H	600H	700H	900H	1100H
Conventional	ℓ	700	940	1070	1350	1350
LSG-H	ℓ	580	580	800	1000	1000

## Innovance 3rd Generation Driver

- Motor encoder control → Enhanced precision control, improving repeatability (previous 2nd generation used resolver control)



## Energy Saving

- Reduced servo motor capacity → Reduces customer facility costs
- Reduced power consumption → Lowers electricity costs



Servo Motor Capacity	Unit	500H	600H	700H	900H	1100H
Conventional	kW	44 + 28	55 + 28	55 + 55	67 + 55	67 + 55
LSG-H	kW	31.7 + 22.3	41.4 + 22.3	58.6 + 31.7	58.6 + 47.5	58.6 + 47.5

## Improved Electrical Layout and Component Quality

- Additional sub-control panel box secures internal space in the control box Increases option utilization, reduces machine wiring assembly time
- Changed electrical components to PUSH-IN type for quality improvement (previously screw connection type = loosening due to vibration)

## Leakage Improvement

- O-Ring Application of O-Ring type Hose Fittings
- Minimization of welded fittings
- Application of FKM sealing Pipe Fittings

**Integrated ONE Solution**   
**Smart Machine for Industry 4.0**  
**Delivering Value**





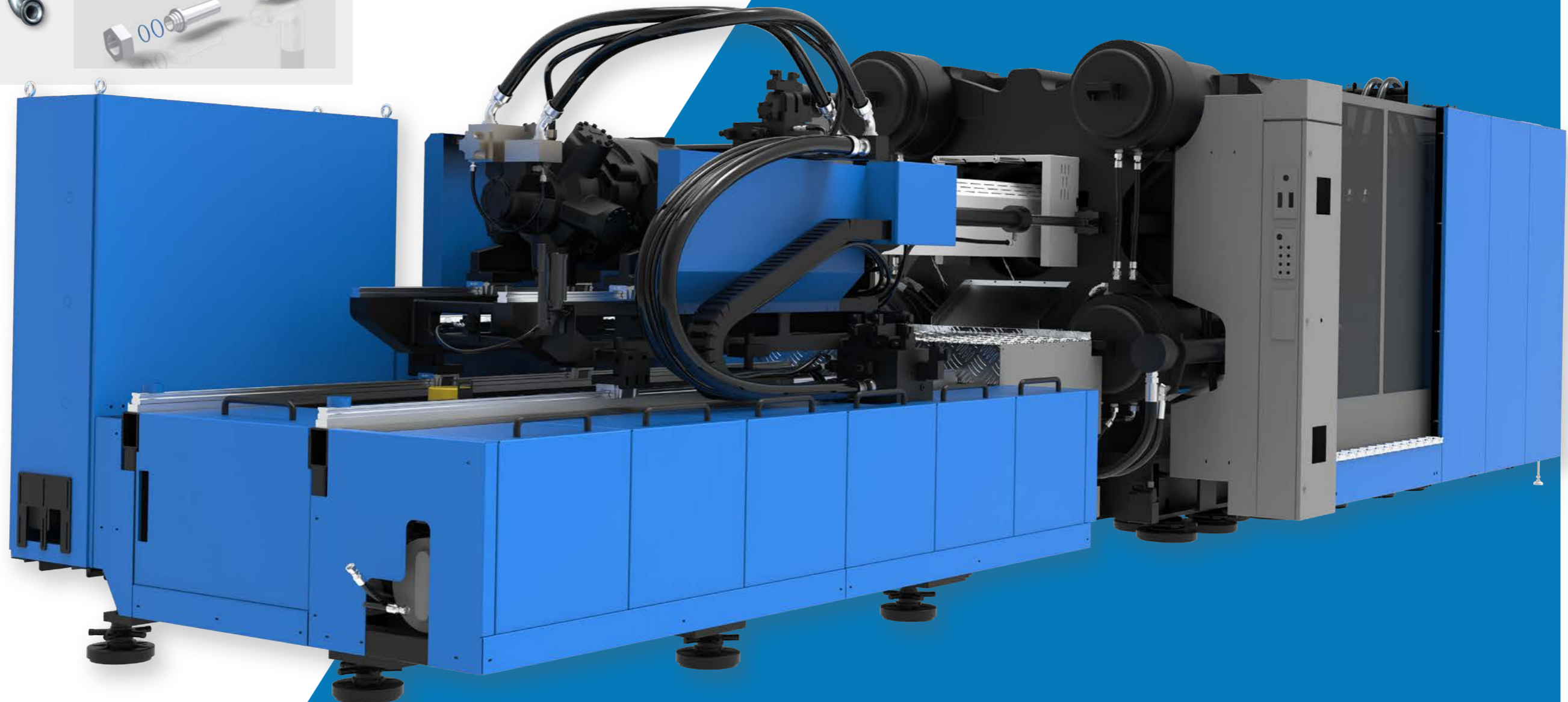

### 1) FKM

To prevent leakage, the machine is equipped with sealing optimized for its molding specification, providing excellent durability.



Large-Tonnage Hybrid Injection Molding Machine

# LSG-H 1500~3500 (US Tons)

-   
 Energy Saving
-   
 Dry Cycle Time Improvement
-   
 Excellent Plasticization
-   
 Low Noise Level
-   
 Large Mold Weight Capacity
-   
 User-Friendly Controller

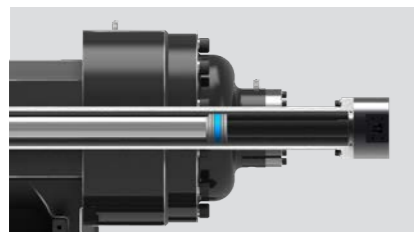
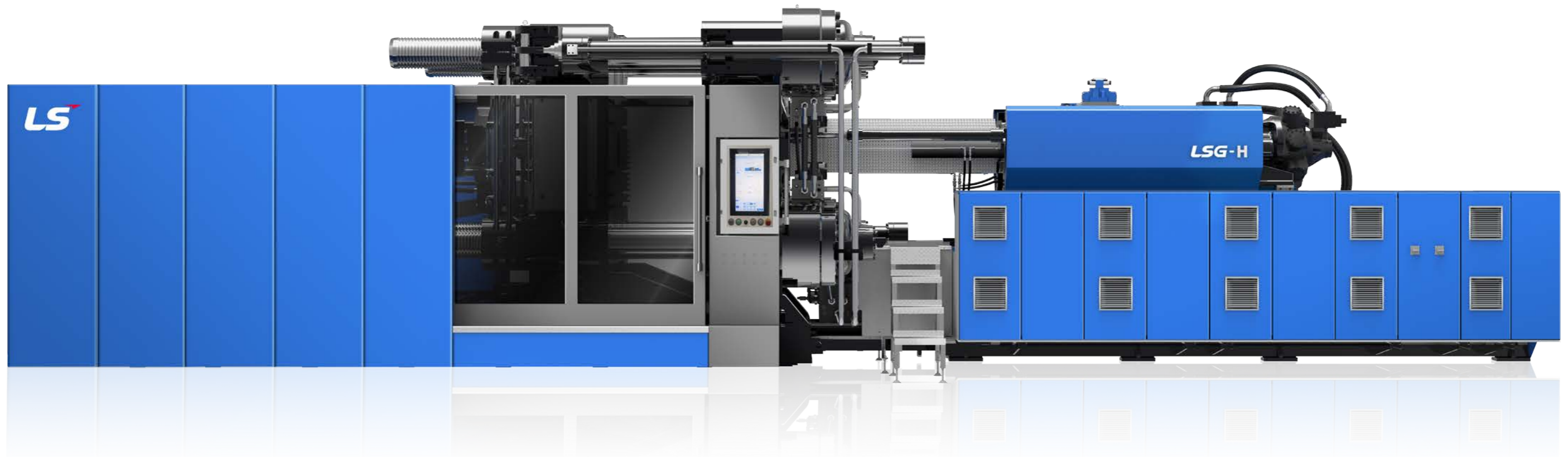

Leak Preventing Clamping Cylinder Design

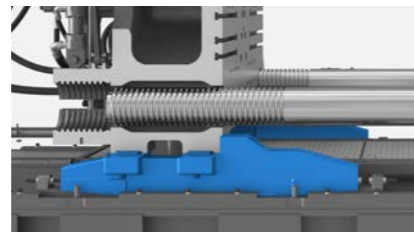

Greaseless Sliding Bushings

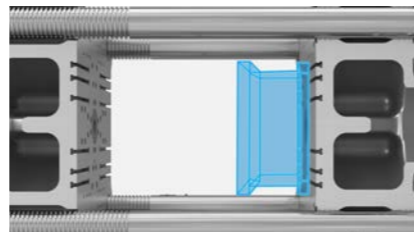

Heavy Mold Capacity

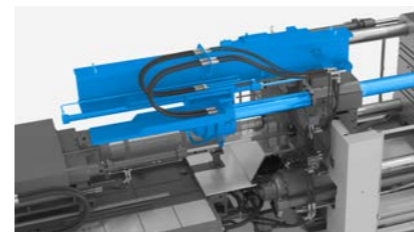

Tie-Bar Pulling System Option

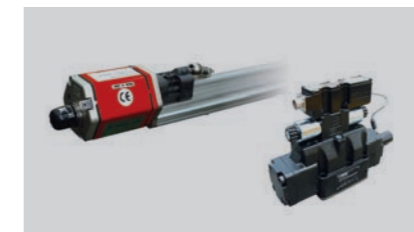

SSI Type High Precision  
- Digital Encoder  
- Large Capacity Electronic Proportional Valve

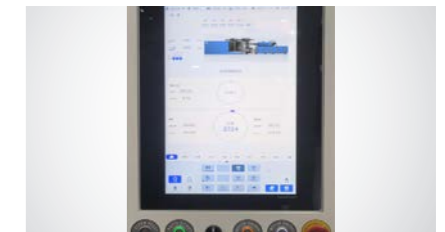

Precision KEBA Controller

## Advanced Repeatability of Mold Open and Close Positions

### High Precision Digital Position Sensor



### High Performance Large Capacity Electromagnetic Proportional Valve

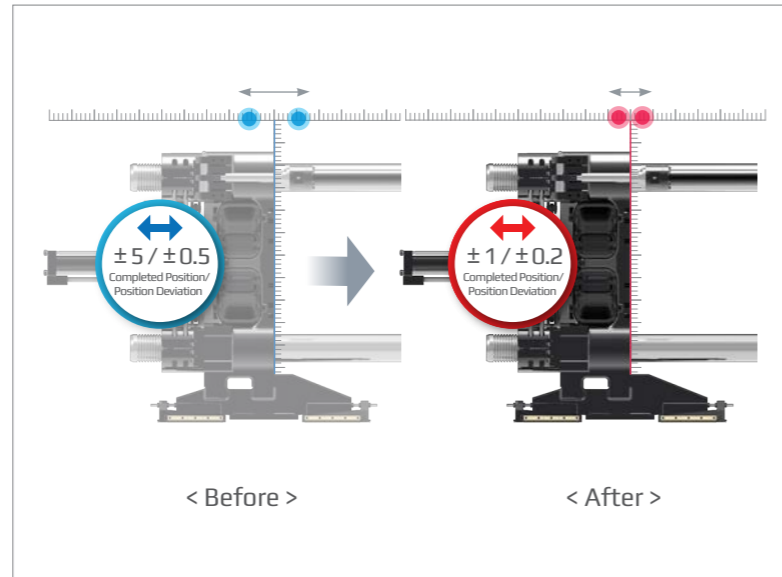

## High Performance Clamp Mechanism

### Tie Bar New Structure

- New Tie Bar Structure
- Integrated Potentiometer

### Improvement in Structure Rigidity and Durability

- Long sliding support of 2% of clamping force for heavy molds
- High Rigidity / Optimized Design
- No Moving Platen Tiebar Bushings

### Applied Lubrication - Free Sliding

- Friction and Wear Minimization
- Shock and Vibration Resistant
- Reduces Maintenance Time & Cost

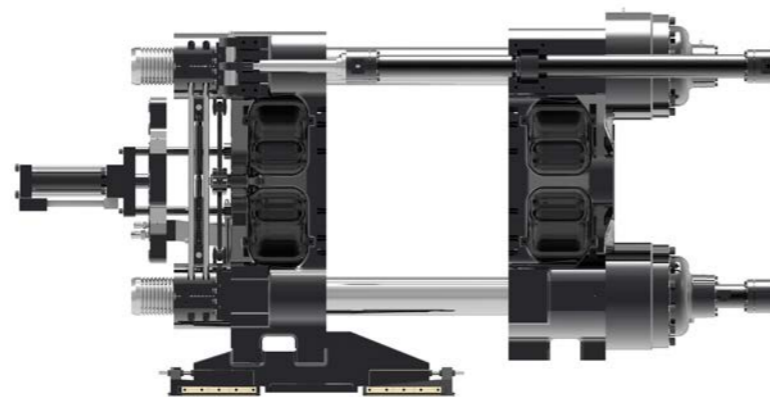

## Enhance Productivity by Reducing Cycle Time

### Improvements to the Mold Opening / Closing Cylinder

- Increased Mold Opening and Closing Speed
- High functional sealing
- New Rod End Bearing and Pin Assembly Design for Improved Cylinder Durability



### Improved Clamping Cylinder Design

- Cutting Edge Seal Technology for Leak Prevention
- Maintains Pressure During Boosting for Power Saving
- Oil Temperature Maintenance Improvement
- Packing cover separation structure application



### Half Nut Design Improvement

- Faster Locking for Cycle Time Reduction
- New Thread Design for Superior Hold
- Stable Half Nut Locking

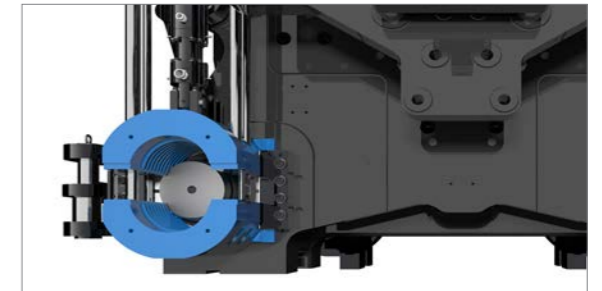

## Tie Bar Pulling System

### Tie Bar Puller Device Option

- One-Touch Tie Bar Retraction
- Easy Mold Changes under Low Ceilings
- Investment Cost Reduction

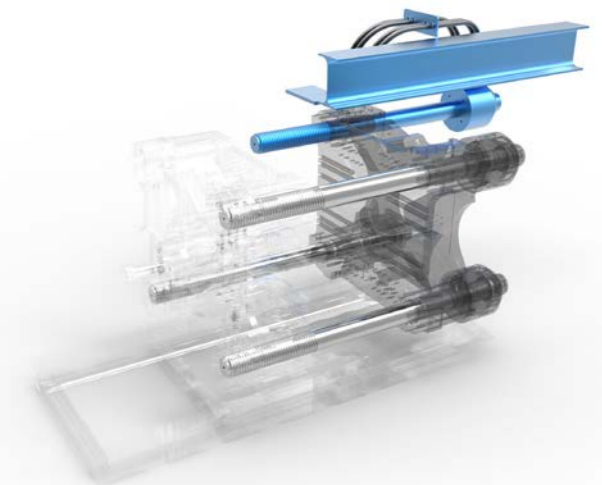

# Injection Unit Innovations

## Injection Unit Movement by Dual Cylinder

- Dual Cylinders for Injection Stability and Resin Leak Prevention
- Extended Life of Hydraulic Cylinders and Injection Unit Components

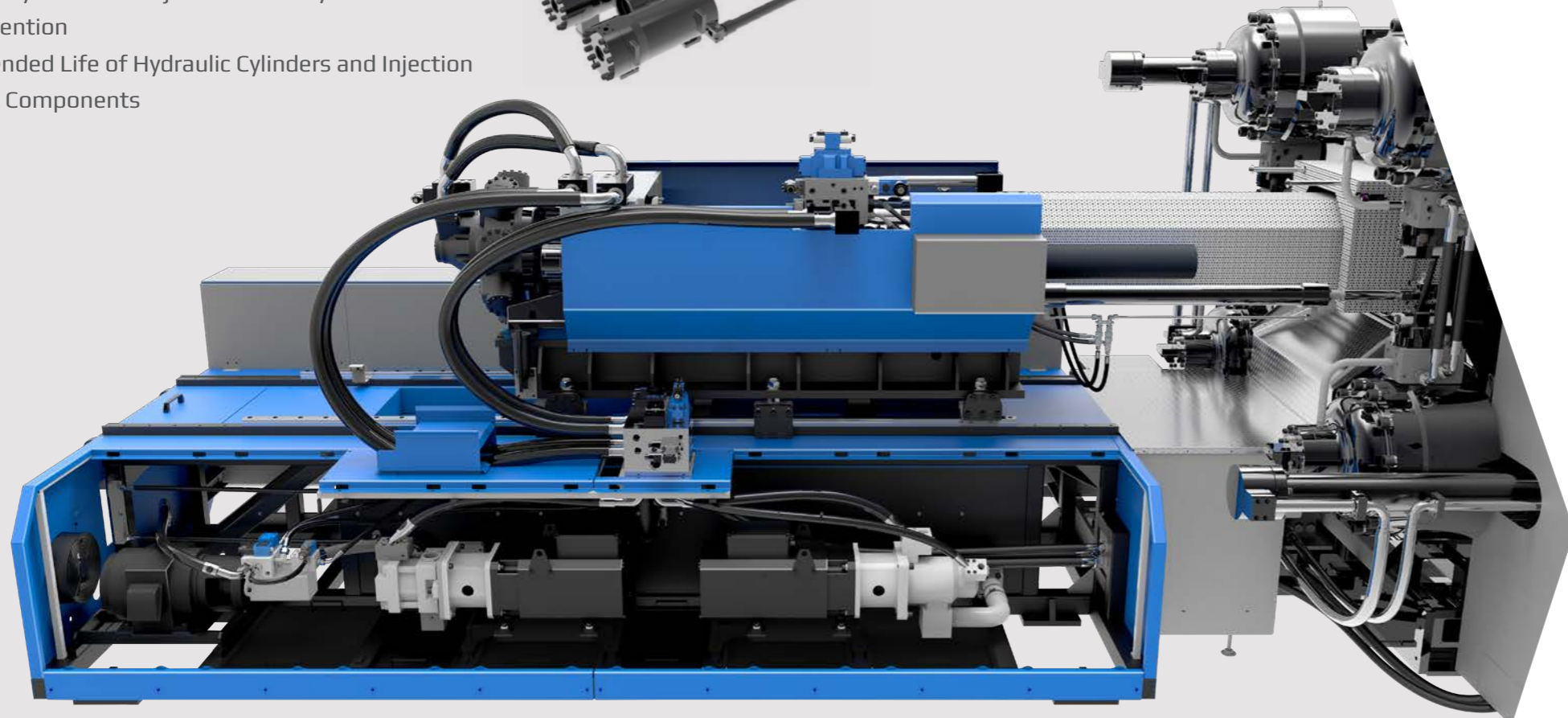

## Easy Modulation Between Screw and Barrels

- Various Options for Shot Size on Same Injection Unit
- High Performance Plasticization

Model	LSG 1500H	LSG 1800H	LSG 2000H	LSG 2300H	LSG 2800H	LSG 3100H	LSG 3500H
i92	95Y	95Y					
	105A*	105A*					
	115B	115B					
i118	105Y	105Y	105Y	105Y			
	115A*	115A*	115A*	115A*			
	125B	125B	125B	125B			
i151	115Y	115Y	115Y	115Y	115Y	115Y	
	125A*	125A*	125A*	125A*	125A*	125A*	
	140B	140B	140B	140B	140B	140B	
i220	125Y	125Y	125Y	125Y	125Y	125Y	125Y
	140A*	140A*	140A*	140A*	140A*	140A*	140A*
	160B	160B	160B	160B	160B	160B	160B
i324					140Y	140Y	140Y
					160A*	160A*	160A*
					180B	180B	180B

Integrated **ONE Solution**  
**Smart Machine for Industry 4.0**  
 Delivering **Value**

## Injection Unit LM Guides

- Accurate Movement Ensures Centered Nozzle Touch



## Barrel Support Option

- Barrel Support Available for Sag Prevention
- Screw & Barrel Life Extension

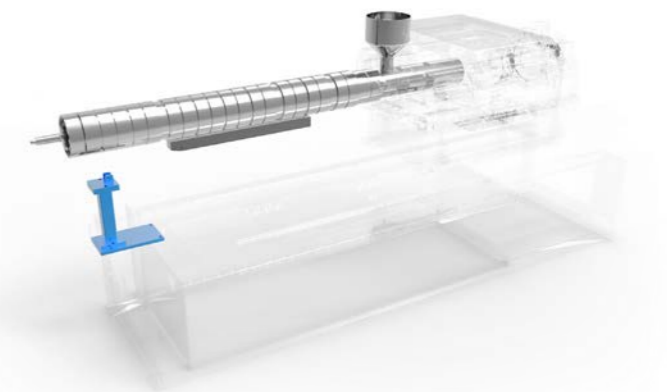

## Easy Maintenance

### Hydraulic Oil Control and Seal Improvement

- New internal structure of the oil tank for Improved Cleanliness
- Epoxy Coating inside Tank also Prevents Rust
- Single Circulation Precision Filtering Device
- Independent Cooling System for Stable Oil Temperature
- Separation return port partition with oil inlet of the oil tank

# CSI 4.0\*

## Connected Smart Injection 4.0 option

LS-Mtron's CSI 4.0 is a solution that can help customers quickly respond to the 4th industrial revolution and digital transformation. The solution starts with accurate data collection, transforming this data into meaningful information, and using data processing technology to improve processes through intelligent applications of AI.

**SMART PRODUCTION**



<p><b>Smart Monitoring</b></p> <p><b>Smart Production Control</b></p> <p><b>Smart Mold Reognition</b></p> <p><b>Smart Equipment Control</b></p> <p><b>Smart Data interface</b></p>	<p>24/7 Mobile Access From Anywhere</p> <p>Real-Time Monitoring Control</p> <p>RFID check and Immediate Upload of Molding Parameters via QR Code</p> <p>Real-time Monitoring</p> <p>Data Transfer to Customer Monitoring Systems</p>
--	--

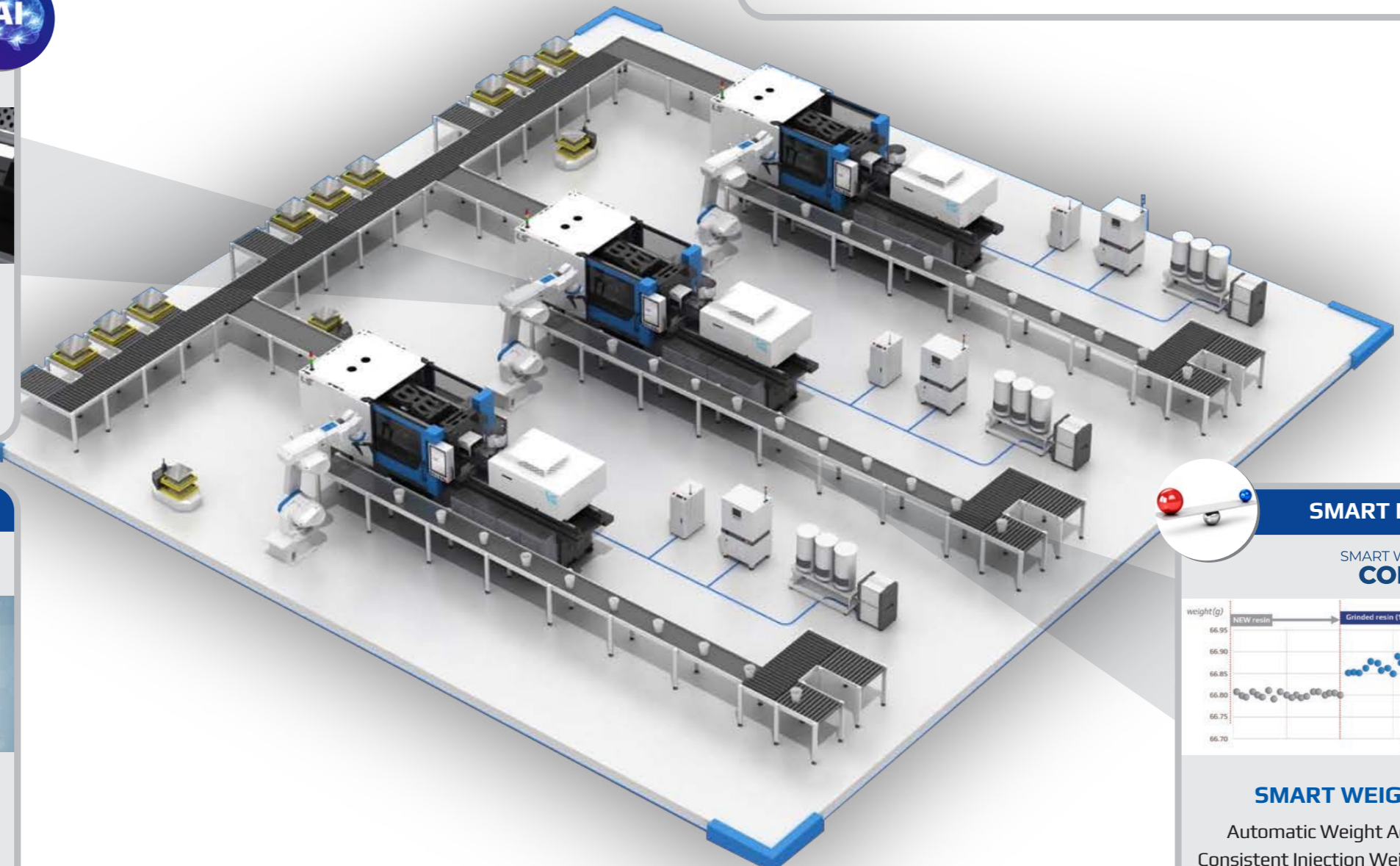

**AI**





**AI Injection System**

AI Molding Assistant

AI Weight Control

Smart Injection Molding Machine

**SMART SERVICE**





**SMART REMOTE SERVICE**

Remotely Monitor

Access and Troubleshoot Machines in Use at Customer Sites

**SMART MACHINE**





**SMART WEIGHT CONTROL**

Automatic Weight Adjustment Maintains Consistent Injection Weight even when Blending with Recycled Resin

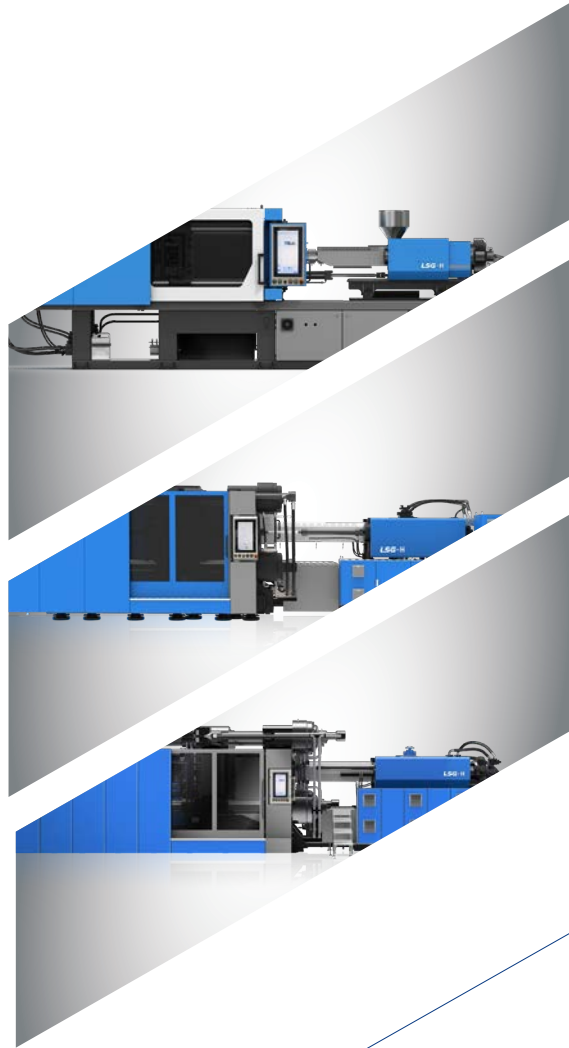

**Headquarters**

Seoul, South Korea

**USA Headquarters**

Duluth, Georgia

**Tel :** +1 (470) 347 3862

**US service :** +1 (800) 843 1672

**Email :** sales@lsinjectionusa.com

**Midwest Tech Center**

Chicago, Illinois

**Tel :** +1 (800) 843-1672

**Email :** sales@lsinjectionusa.com

**West Coast Tech Center**

Anaheim, California

**Tel :** +1 (714) 743-0906

**Mexico HQ & Tech Center**

Apodaca, Nuevo Leon

**Mexico Sales & Service**

Queretaro & Tijuana



**ONAS18001**

